

# TP PITCH DIAMETER BASE STUD

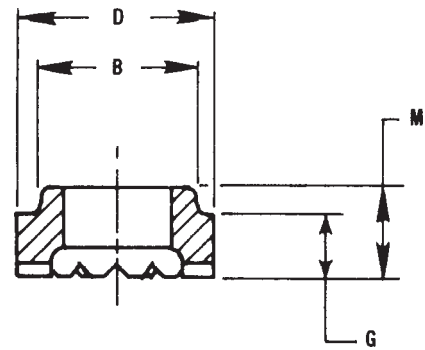
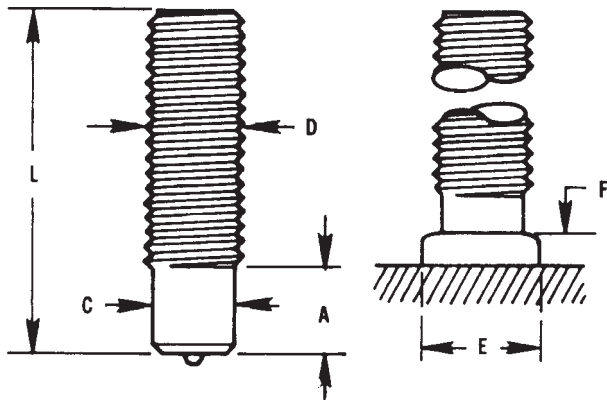

STUD SPECIFICATIONS						FERRULE SPECIFICATIONS				
D	Min L.	C	A	FILLET DIMENSION		No.	D	B	G	M
				E	F					
1/4-20	5/8	.215	3/8	5/16	3/32	14PFER	.455	.385	.125	.250
5/16-18	43/64	.275	3/8	13/32	7/64	51PFER	.535	.445	.125	.250
3/8-16	27/32	.330	3/8	15/32	7/64	38PFER	.590	.505	.139	.264
7/16-14	15/16	.387	7/16	17/32	1/8	71PFER	.675	.585	.173	.329
1/2-13	1 1/32	.448	1/2	19/32	5/32	12PFER	.740	.650	.206	.362
5/8-11	1 13/64	.562	5/8	3/4	3/16	58PFER	.910	.785	.277	.433
3/4-10	1 7/16	.680	51/64	59/64	1/4	34PFER	1.150	1.030	.339	.526
7/8-9	1 39/64	.798	55/64	1 3/64	5/16	78PFER	1.330	1.210	.406	.593
1-8	1 51/64	.915	59/64	1 3/16	11/32	1PFER	1.526	1.406	.474	.661

COX INDUSTRIES TP STUDS have a pitch diameter weld base (C). They are available in diameters 1/4" through 1". All orders for studs include required ferrules.

LENGTH: Available in required lengths above recommended standard minimums (L). Length is before weld. Stud diameters 1/2" and below will be approximately 1/8" shorter after welding. 5/8" and above will be approximately 3/16" shorter after welding.

THREAD: Standard thread is UNC2A. Maximum standard thread length is 3 7/8".

MATERIAL: Low carbon steel.

Mechanical Properties (as cold drawn)  
 Tensile .....55,000 psi min.  
 Reduction in Area .....50% min.

STAINLESS STEELS: COX INDUSTRIES studs are also available in weldable stainless steel. Type 304 is the most commonly used. Other grades of stainless steel (except Type 303) available when required.

PLATING: If plated studs are required, cadmium, zinc, and nickel are used to ASTM specifications A165 Type TS, A164 Type RS, and B-456. Welding end of stud is not plated to prevent weld contamination. Information on other plating materials available upon request.

ANNEALING: Stud ductility can be increased by annealing to 75 Rockwell B for low carbon steel and 90 Rockwell B for stainless steel.

FLUX: COX INDUSTRIES studs 1/4" and over are solid fluxed.



Cox Industries