

TF FULL THREADED STUD

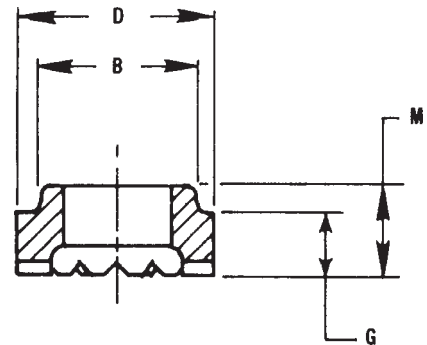
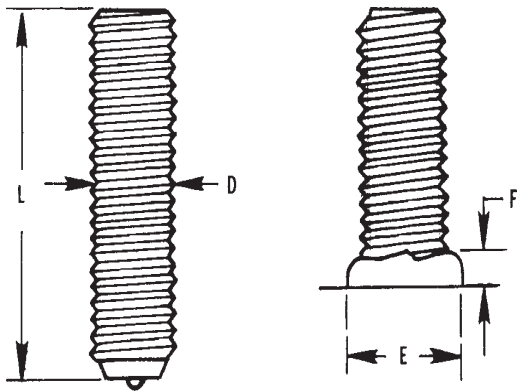

STUD SPECIFICATIONS				FERRULE SPECIFICATIONS				
D	Min L.	FILLET DIMENSION		No.	D	B	G	M
		E	F					
10-24	5/8	9/32	3/32	10FER	.390	.305	.234	.390
1/4-20	43/64	23/64	7/64	14FER	.454	.380	.234	.390
5/16-18	27/32	7/16	7/64	51FER	.578	.445	.281	.437
3/8-16	15/16	1/2	1/8	38FER	.637	.505	.281	.437
7/16-14	1 1/32	19/32	5/32	71FER	.703	.585	.234	.422
1/2-13	1 13/64	11/16	3/16	12FER	.795	.650	.281	.469
5/8-11	1 7/16	7/8	1/4	58FER	1.030	.785	.328	.516
3/4-10	1 39/64	1 1/16	5/16	34FER	1.215	1.030	.469	.656
7/8-9	1 51/64	1 1/8	11/32	78FER	1.408	1.210	.545	.732
1-8	1 17/32	1 3/8	3/8	1FER	1.615	1.406	.633	.820

COX INDUSTRIES TF STUDS are available in diameters 3/16" through 1". All orders for studs include required ferrules.

LENGTH: Available in required lengths above recommended standard minimums (L). Length is before weld. Stud diameters 1/2" and below will be approximately 1/8" shorter after welding. 5/8" and above will be approximately 3/16" shorter after welding.

THREAD: Standard thread is UNC2A. Maximum standard thread length is 3 7/8".

MATERIAL: Low carbon steel.

Mechanical Properties (as cold drawn)
 Tensile55,000 psi min.
 Reduction in Area50% min.

STAINLESS STEELS: COX INDUSTRIES studs are also available in weldable stainless steel. Type 304 is the most commonly used. Other grades of stainless steel (except Type 303) available when required.

PLATING: If plated studs are required, cadmium, zinc, and nickel are used to ASTM specifications A165 Type TS, A164 Type RS, and B-456. Welding end of stud is not plated to prevent weld contamination. Information on other plating materials available upon request.

ANNEALING: Stud ductility can be increased by annealing to 75 Rockwell B for low carbon steel and 90 Rockwell B for stainless steel.

FLUX: COX INDUSTRIES studs 1/4" and over are solid fluxed.



Cox Industries