

REC RECTANGULAR STUDS

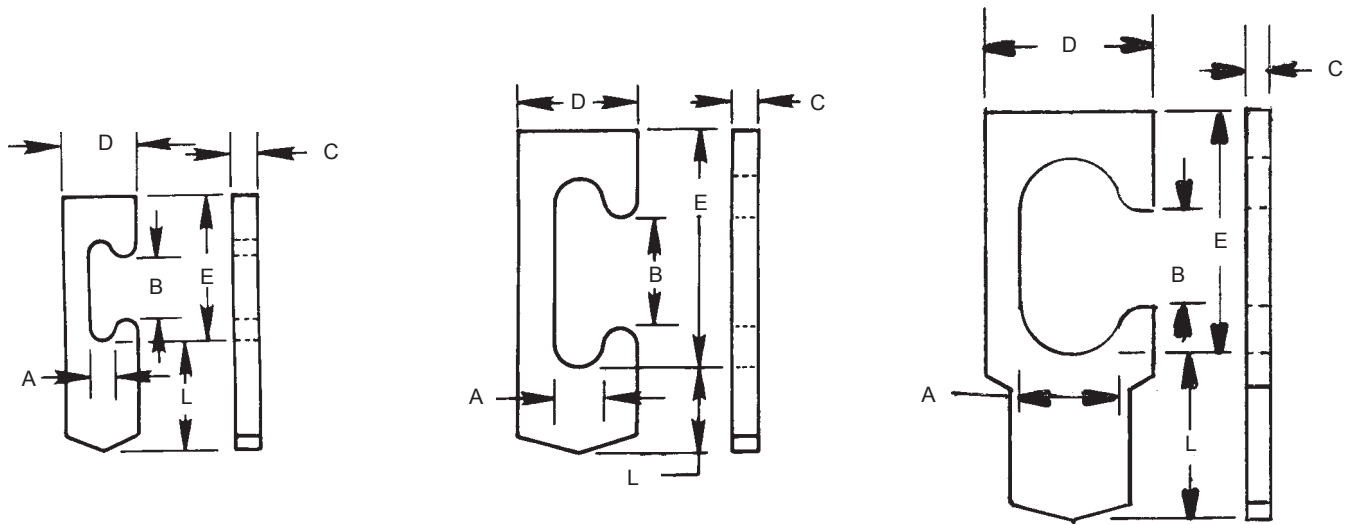

STUD SPECIFICATIONS					
D	Min. L	C	A	B	E
3/8	1/4	1/8	.130	.34	.74
5/8	5/16	1/8	.255	.5	1.25
7/8	7/8	1/8	.505	.5	1.25

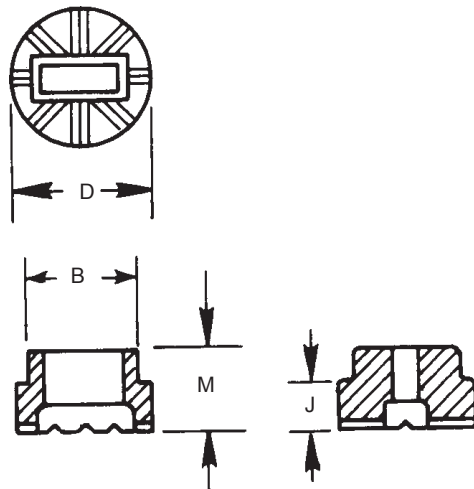

FERRULE SPECIFICATIONS				
STUD SIZE	D	B	M	J
3/8	.640	.505	.390	.234
5/8 & 7/8	1.093	.916	.436	.234



Cox Industries